

次のそれぞれの図形の面積を求めなさい。

1.

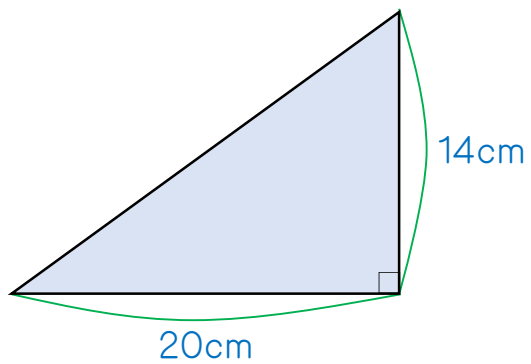

2.

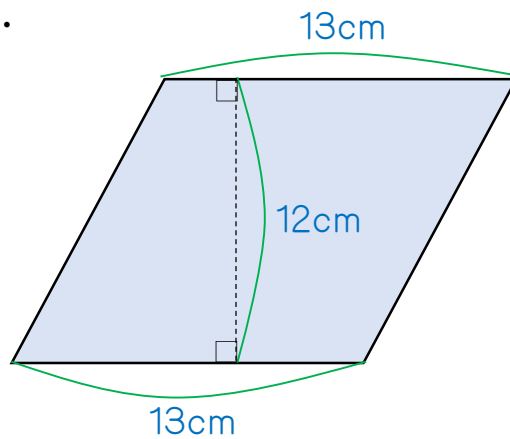

3.

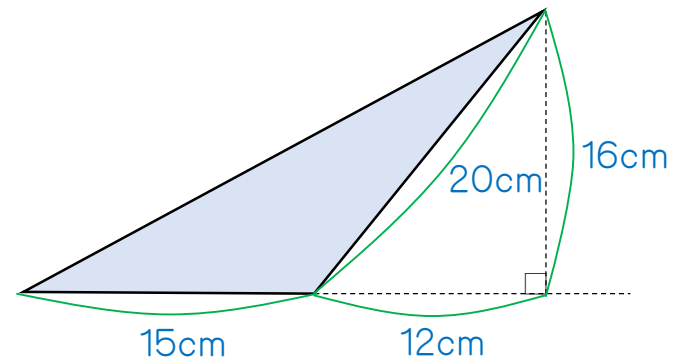

4.

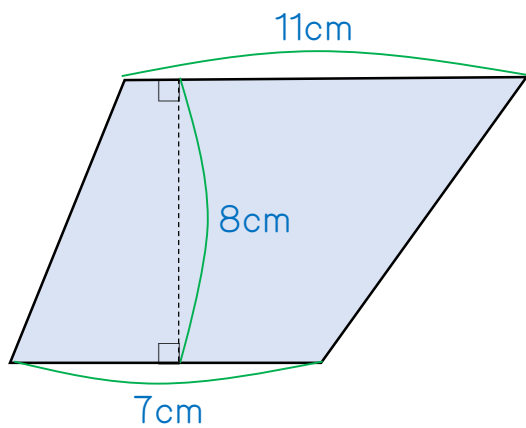

5.

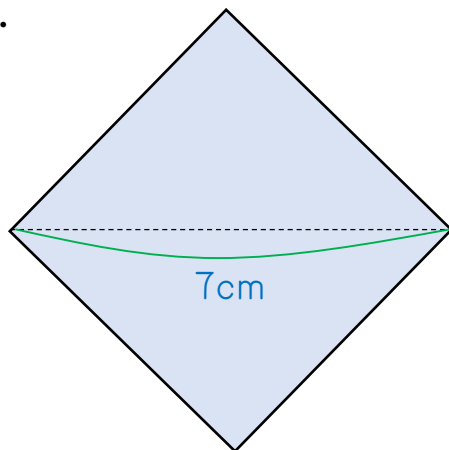

←正方形

6.

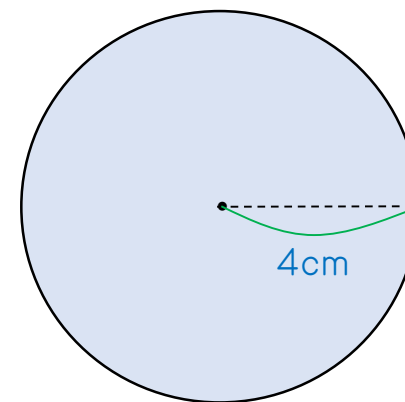

次のそれぞれの図形の面積を求めなさい。

7.

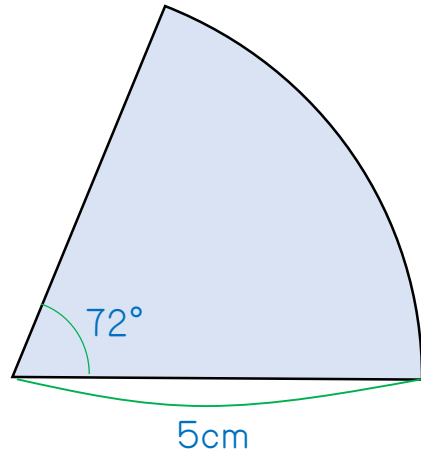

8.

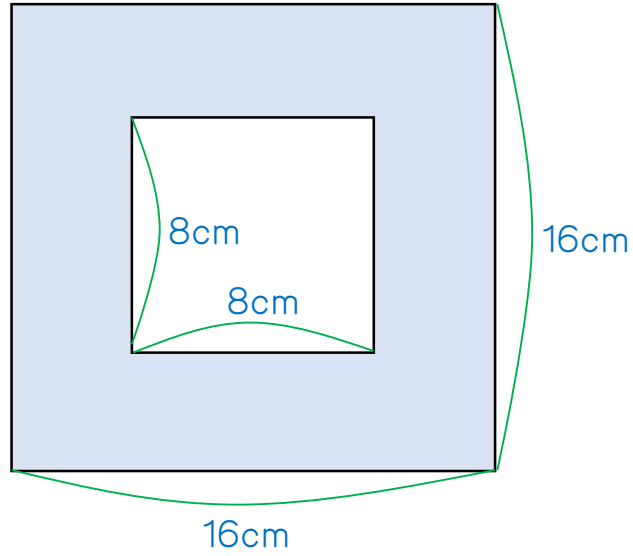

9.

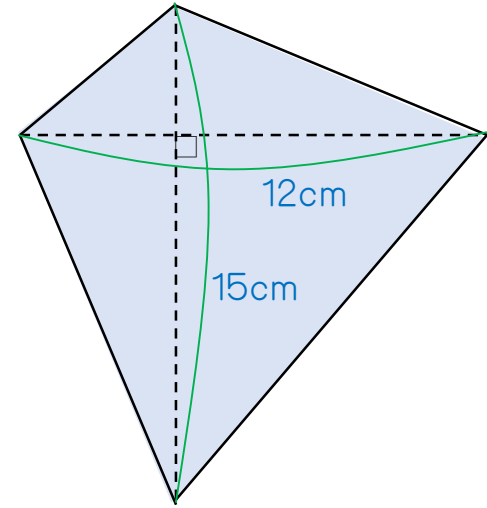

10.

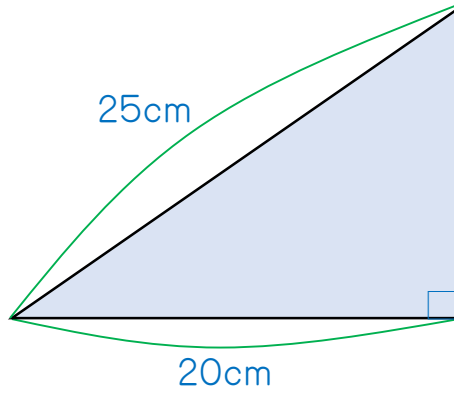

1. 140cm^2

2. 156cm^2

3. 120cm^2

4. 72cm^2

5. 49.5cm^2

6. 50.24cm^2

7. 15.7cm^2

8. 192cm^2

9. 90cm^2

10. 150cm^2